



LC2632

28V, 2A, 500KHz Synchronous Step-Down DC/DC Converter

DESCRIPTION

The LC2632 is a fully integrated, synchronous rectified step-down converter that provides wide 4.2V to 28V input voltage range and 2A continuous load current capability. The LC2632 can operate at PFM mode to achieve high efficiency and reduce power loss at light load. In shutdown mode, the Max supply current is about 3μA.

The LC2632 protection function includes cycle-by-cycle current limit, UVLO and thermal shutdown. Besides, internal soft-start prevents inrush current at fast power-on. This device uses slope compensated current mode control which provides fast load transient response. Internal loop compensation function reduces the external compensator components and simplifies the design process.

The LC2632 requires a minimum number of readily available standard external components and is available in ESOP-8 (Exposed Pad) package and provides good thermal conductance.

FEATURES

- Wide input voltage range: 4.2V to 28V
- 2A output current
- 0.8V reference voltage
- Low $R_{DS(ON)}$ integrated power MOSFET (180/110mΩ)
- 3μA(Max) shutdown current
- Integrated internal compensation
- High efficiency at light load
- Internal 1ms soft-start
- Cycle-by-cycle current limit
- Over-temperature protection with auto recovery
- Under voltage lockout(UVLO)
- Hiccup short circuit protection
- Available in ESOP8 exposed pad package
- RoHS compliant

APPLICATIONS

- Distributed power system
- Flat panel television and monitors
- STB (set-top-box)
- Networking, XDSL modem

PIN OUT & MARKING

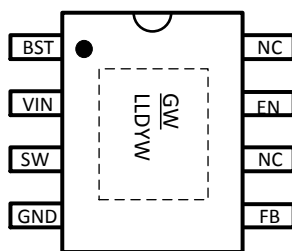

ESOP8

GW: Product Code
LL: Lot No.
D: Fab code
YW: Date code

ORDERING INFORMATION

PART No.	LC2632CS8TR
PACKAGE	ESOP-8
Tape&Reel	2500/Reel

TYPICAL APPLICATION

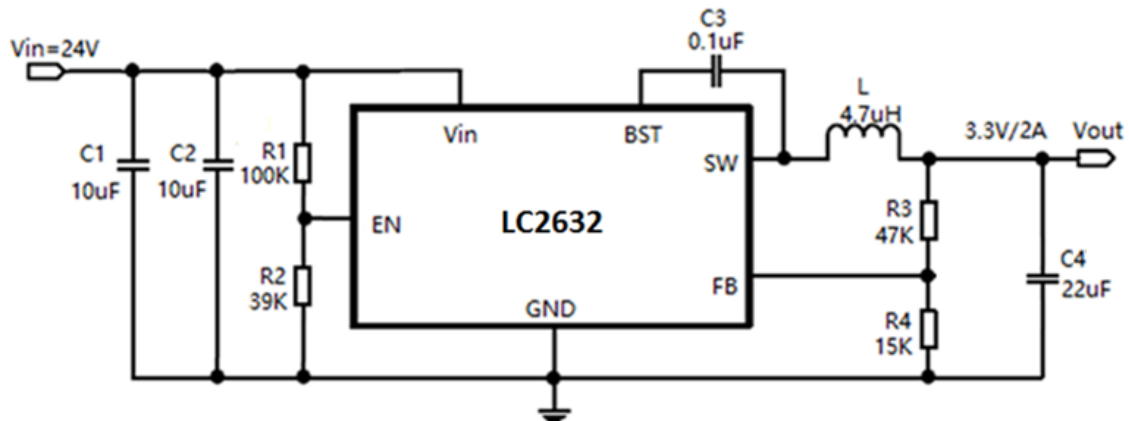

C_{IN} & C_{OUT} use ceramic capacitors application circuit

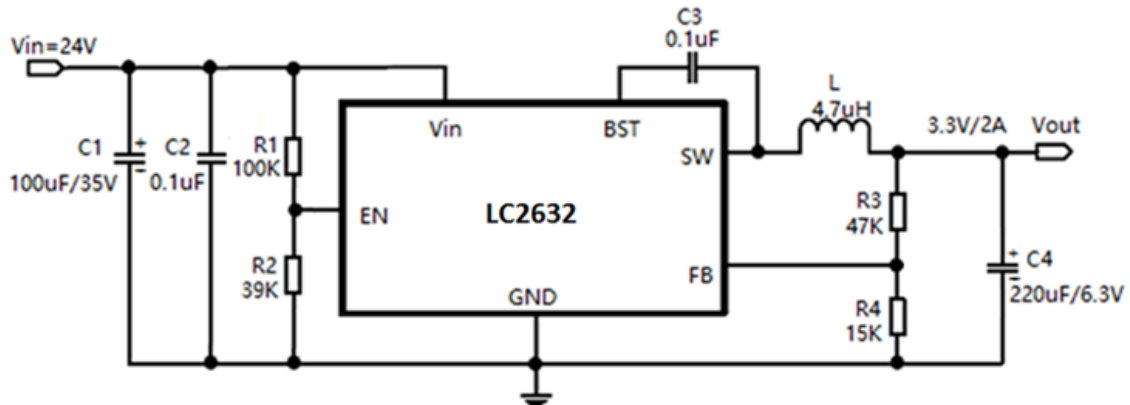

C_{IN} & C_{OUT} use electrolytic capacitors application circuit

Note: If the input voltage is below 12V, R1 can be set to 0K and R2 can be removed.

Table1. recommended component values

V_{IN}=24V, the recommended BOM list is shows as below.

V _{OUT}	C1	C2	L	R3	R4	C5
5V	10uF/MLCC	10uF/MLCC	3.3uH-6.8uH	68K	13K	22uF/MLCC
3.3V			2.2uH-4.7uH	47K	15K	
2.8V			2.2uH-4.7uH	30K	12K	
2.5V			2.2uH-4.7uH	39K	18K	
1.8V			2.2uH-4.7uH	15K	12K	
1.2V			2.2uH-3.3uH	7.5K	15K	
5V	100uF/35V/ECL	0.1uF/MLCC	3.3uH-6.8uH	68K	13K	220uF/6.3V/ECL
3.3V			2.2uH-4.7uH	47K	15K	
2.8V			2.2uH-4.7uH	30K	12K	
2.5V			2.2uH-4.7uH	39K	18K	
1.8V			2.2uH-3.3uH	15K	12K	
1.2V			2.2uH-3.3uH	7.5K	15K	

ABSOLUTE MAXIMUM RATING

Parameter	Value
Supply voltage V_{IN}	-0.3V to 30V
Switch node voltage V_{SW}	-0.3V to ($V_{IN}+0.5V$)
Boost voltage V_{BST}	$V_{SW}-0.3V$ to $V_{SW}+5V$
Enable voltage V_{EN}	-0.3V to 12V
The others pins	-0.3V to 6V
Operating temperature range	-40°C to 85°C
Storage temperature range	-65°C to 150°C
Lead temperature (soldering, 10s)	300°C

Note: Exceed these limits to damage to the device. Exposure to absolute maximum rating conditions may affect device reliability.

RECOMMENDED WORK CONDITIONS

Item	Min	Recommended	Max.	Unit
Supply voltage V_{IN}	4.2		28	V
Ambient temperature	-40		85	°C

ELECTRICAL CHARACTERISTICS

($V_{IN} = 12V$, $T_A = 25^\circ C$, unless otherwise stated)

Parameter	Conditions	Min	Typ	Max	Unit
Input voltage range		4.2		28	V
UVLO threshold	Vin rising		3.8		V
UVLO hysteresis	Vin falling		200		mV
Supply current in operation	$V_{EN} = 5V$, $V_{FB} = 1V$		150		uA
Supply current in shutdown	$V_{EN} = 0V$		1		uA
Regulated feedback voltage	$3.8V \leq V_{IN} \leq 28V$	0.784	0.8	0.816	V
High-side switch on resistance	$V_{BST-SW} = 5V$		180		mΩ
Low-side switch on resistance	$V_{IN} = 5V$		110		mΩ
High-side switch leakage current	$V_{EN} = 0V$, $V_{SW} = 0V$		0.1	10	uA
Upper switch current limit	Minimum duty cycle	3			A
Oscillation frequency			500		KHz
Maximum duty cycle			93		%
Minimum on time			100		ns
EN input voltage "H"		1.5			V
EN input voltage "L"				0.6	V
Thermal shutdown			160		°C

PIN DESCRIPTION

PIN #	NAME	DESCRIPTION
1	BST	High side power transistor gate drive boost input.
2	VIN	Power input. Bypass with a 22uF ceramic capacitor to GND.
3	SW	Power switching node to connect inductor.
4	GND	Ground.
5	FB	Feedback input with reference voltage set to 0.8V.
6	NC	No connection
7	EN	Enable input. Set this pin to high level to enable the part, low level to disable.
8	NC	No connection
9	Thermal PAD	Ground. The exposed pad must be soldered to a large PCB area and connected to GND for maximum power dissipation.

ELECTRICAL PERFORMANCE

Efficiency vs. Iout
Vout=1.2V

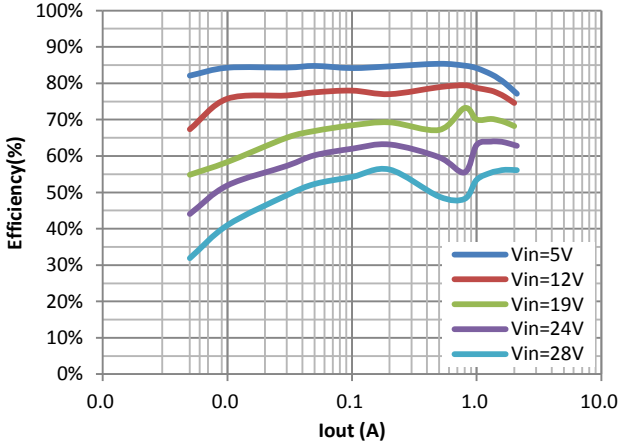

Efficiency vs. Iout
Vout=3.3V

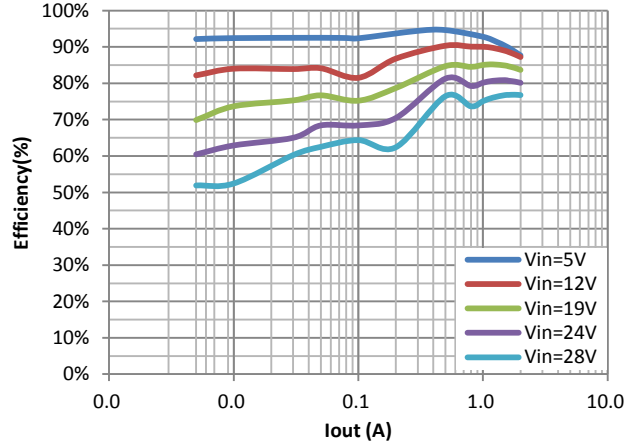

Efficiency vs. Iout
Vout=5.0V

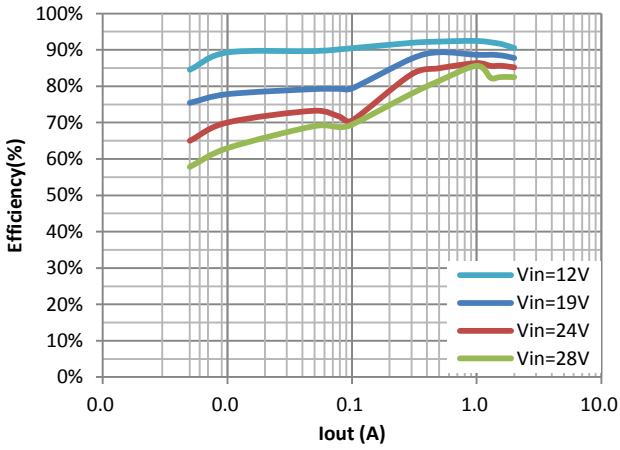

Vout vs. Iout
Vout=1.2V

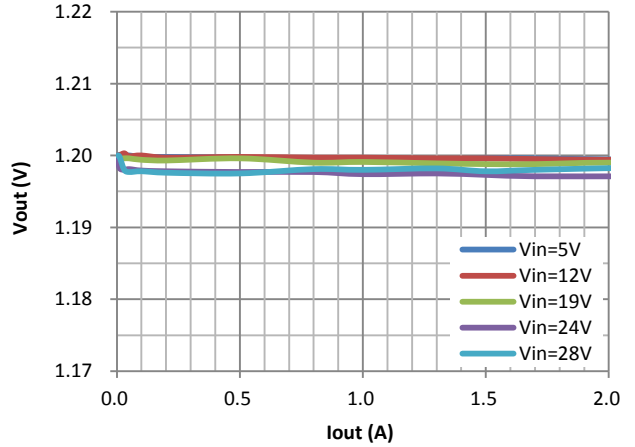

Vout vs. Iout
Vout=3.3V

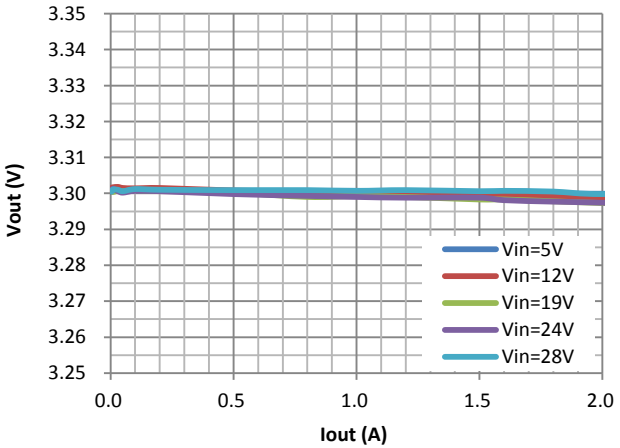

Vout vs. Iout
Vout=5.0V

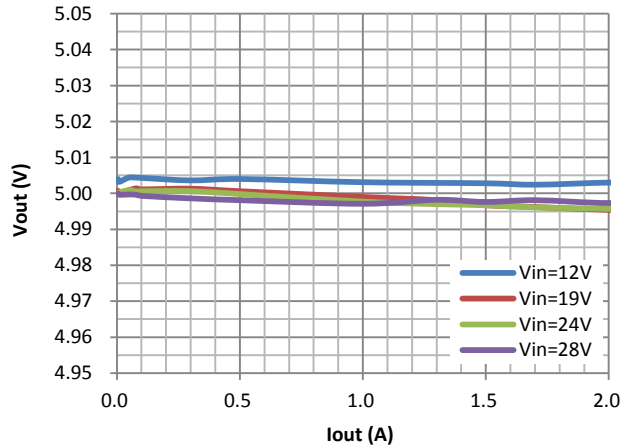

Steady State Waveform

Vin=12V, Vout=3.3V, Cin=Cout=10uF*2, L=4.7uH, Iout=0A
 Ch1—Vin, Ch2—Vout, Ch3—V_{sw}, Ch4—I_{sw}

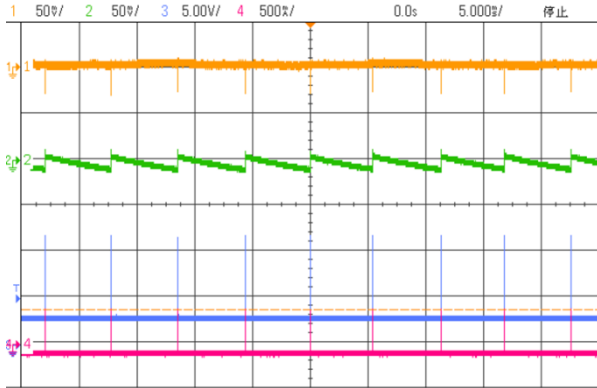

Steady State Waveform

Vin=12V, Vout=3.3V, Cin=Cout=10uF*2, L=4.7uH, Iout=2A
 Ch1—Vin, Ch2—Vout, Ch3—V_{sw}, Ch4—I_{sw}

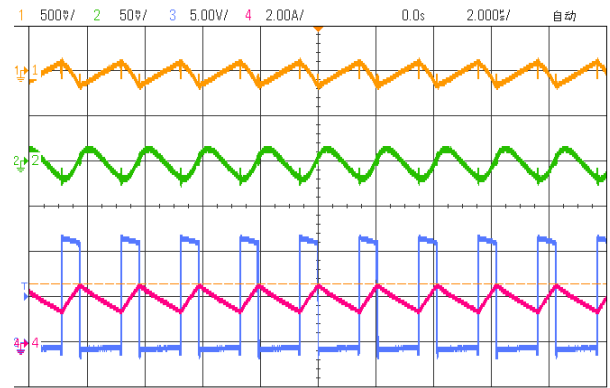

Load Transient

Vin=12V, Vout=3.3V, Iout=0.01~1A
 Ch2—Vout, Ch4—I_L

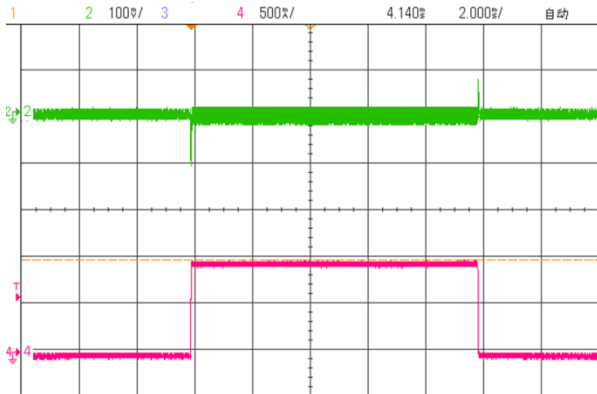

Load Transient

Vin=12V, Vout=3.3V, Iout=1~2A
 Ch2—Vout, Ch4—I_L

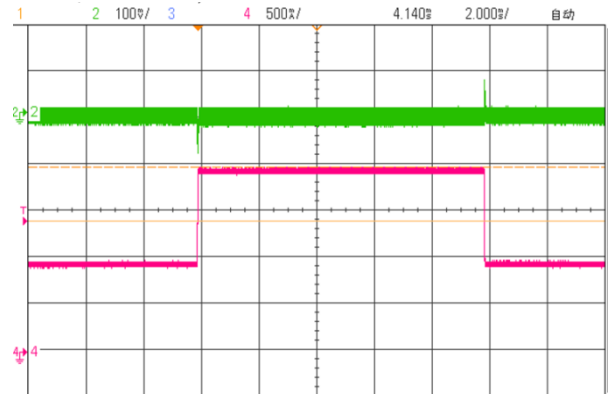

BLOCK DIAGRAM

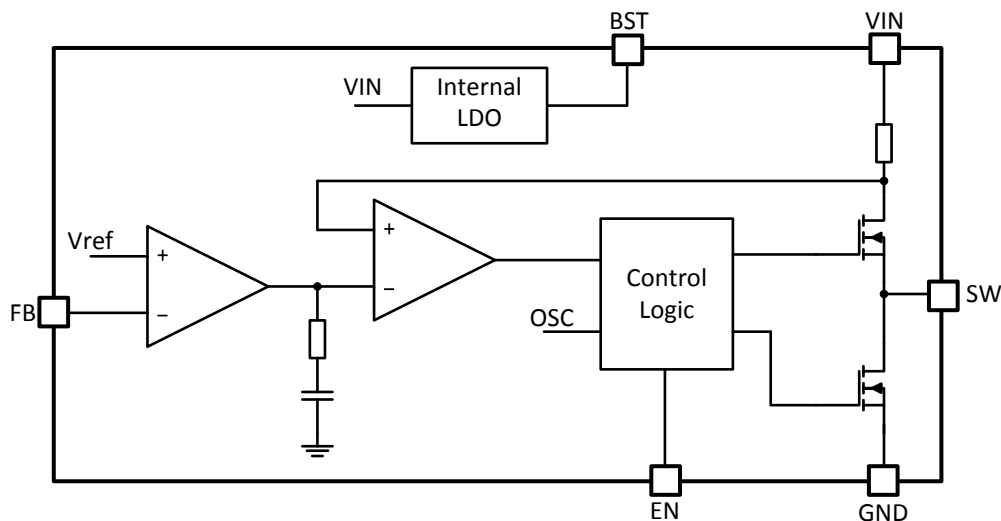

FUNCTIONAL DESCRIPTIONS

Loop operation

The LC2632 is a wide input range, high-efficiency, DC-to-DC step-down switching regulator, capable of delivering up to 2A of output current, integrated with a 180/110mΩ synchronous MOSFET pair, eliminating the need for external diode. It uses a PWM current-mode control scheme. An error amplifier integrates error between the FB signal and the internal reference voltage. The output of the integrator is then compared to the sum of a current-sense signal and the slope compensation ramp. This operation generates a PWM signal that modulates the duty cycle of the power MOSFETs to achieve regulation for output voltage.

Internal soft-start

The soft-start is important for many applications because it eliminates power-up initialization problems. The controlled voltage ramp of the output also reduces peak inrush current during start-up, minimizing start-up transient events to the input power bus.

Over-current-protection and hiccup

The LC2632 has a cycle-by-cycle over-current limit for when the inductor current peak value exceeds the set current-limit threshold. First, when the output voltage drops until FB falls below the Under-Voltage (UV) threshold (typically 300mV) to trigger a UV event, the LC2632 enters hiccup mode to periodically restart the part. This protection mode is especially useful when the output is dead-shortened to ground. This

greatly reduces the average short-circuit current to alleviate thermal issues and to protect the regulator. The LC2632 exits hiccup mode once the overcurrent condition is removed.

Light load operation

Traditionally, a fixed constant frequency PWM DC-DC regulator always switches even when the output load is small. When energy is shuffling back and forth through the power MOSFETs, power is lost due to the finite RDSOns of the MOSFETs and parasitic capacitances. At light load, this loss is prominent and efficiency is therefore very low. LC2632 employs a proprietary control scheme that improves efficiency in this situation by enabling the device into a power save mode during light load, thereby extending the range of high efficiency operation.

Startup and shutdown

If both VIN and EN are higher than their appropriate thresholds, the chip starts. The reference block starts first, generating stable reference voltage and currents, and then the internal regulator is enabled. The regulator provides stable supply for the remaining circuitries. Three events can shut down the chip: EN low, VIN low and thermal shutdown. In the shutdown procedure, the signaling path is first blocked to avoid any fault triggering. The COMP voltage and the internal supply rail are then pulled down. The floating driver is not subject to this shutdown command.

APPLICATIONS INFORMATION

Setting output voltages

The external resistor divider is used to set the output voltage. The feedback resistor R1 also sets the feedback loop bandwidth with the internal compensation capacitor. R2 is then given by:

$$R_2 = \frac{R_1}{V_{out}/V_{FB} - 1}$$

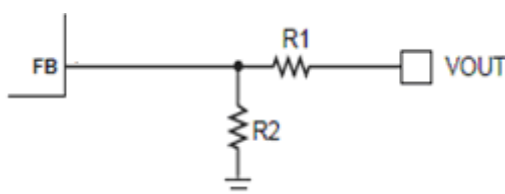

Selecting the inductor

Use a 2.2μH-to-6.8μH inductor with a DC current rating of at least 25% higher than the maximum load current for most applications. For most designs, derive the inductance value from the following equation:

$$L = \frac{V_{OUT} \times (V_{IN} - V_{OUT})}{V_{IN} \times \Delta I_L \times f_{osc}}$$

Where ΔIL is the inductor ripple current. Choose an inductor current approximately 30% of the maximum load current. The maximum inductor peak current is:

$$I_{L(MAX)} = I_{LOAD} + \frac{\Delta I_L}{2}$$

Under light-load conditions (below 100mA), use a larger inductor to improve efficiency.

Selecting the output capacitor

The output capacitor maintains the DC output voltage. Use ceramic, tantalum, or low-ESR electrolytic capacitors. Use low ESR capacitors to limit the output voltage ripple. Estimate the output voltage ripple with:

$$\Delta V_{OUT} = \frac{V_{OUT}}{f_S \times L} \times \left[1 - \frac{V_{OUT}}{V_{IN}} \right] \times \left[R_{ESR} + \frac{1}{8 \times f_S \times C_2} \right]$$

Where L is the inductor value and R_{ESR} is the equivalent series resistance (ESR) of the output capacitor.

For ceramic capacitors, the capacitance dominates the impedance at the switching frequency and causes most of the output voltage ripple. For simplification, estimate the output voltage ripple with:

$$\Delta V_{OUT} = \frac{V_{OUT}}{8 \times f_S^2 \times L \times C_2} \times \left[1 - \frac{V_{OUT}}{V_{IN}} \right]$$

For tantalum or electrolytic capacitors, the ESR dominates the impedance at the switching

PCB LAYOUT RECOMMENDATION

The device's performance and stability are dramatically affected by PCB layout. It is recommended to follow these general guidelines shown as below:

1. Place the input capacitors and output capacitors as close to the device as possible. The traces which connect to these capacitors should be as short and wide as possible to minimize parasitic inductance and resistance.
2. Place feedback resistors close to the FB pin.
3. Keep the sensitive signal (FB) away from the switching signal (SW).
4. The exposed pad of the package should be soldered to an equivalent area of metal on the PCB. This area should connect to the GND plane and have multiple via connections to the back of the PCB as well as connections to intermediate PCB

frequency. For simplification, the output ripple can be approximated with:

$$\Delta V_{OUT} = \frac{V_{OUT}}{f_S \times L} \times \left[1 - \frac{V_{OUT}}{V_{IN}} \right] \times R_{ESR}$$

The characteristics of the output capacitor also affect the stability of the regulation system. The LC2632 can be optimized for a wide range of capacitance and ESR values.

Selecting the external boost diode

It is recommended to add an external Boost Diode to improve efficiency and stability in these situations when the input voltage is fixed at 5.0V. Any a readily and cheap diode can meet the need of these application such as 1N4148.

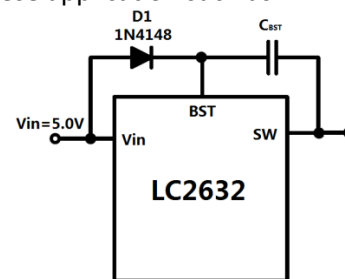

layers. The GND plane area connecting to the exposed pad should be maximized to improve thermal performance.

5. Multi-layer PCB design is recommended.

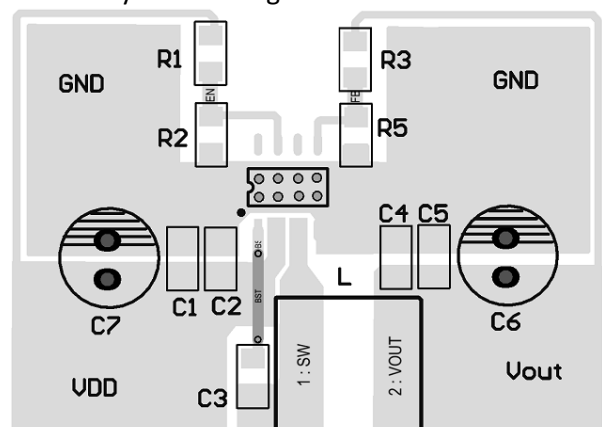

PACKAGE OUTLINE

Package	ESOP8	Devices per reel	2500	Unit	mm
---------	-------	------------------	------	------	----

Package specification:

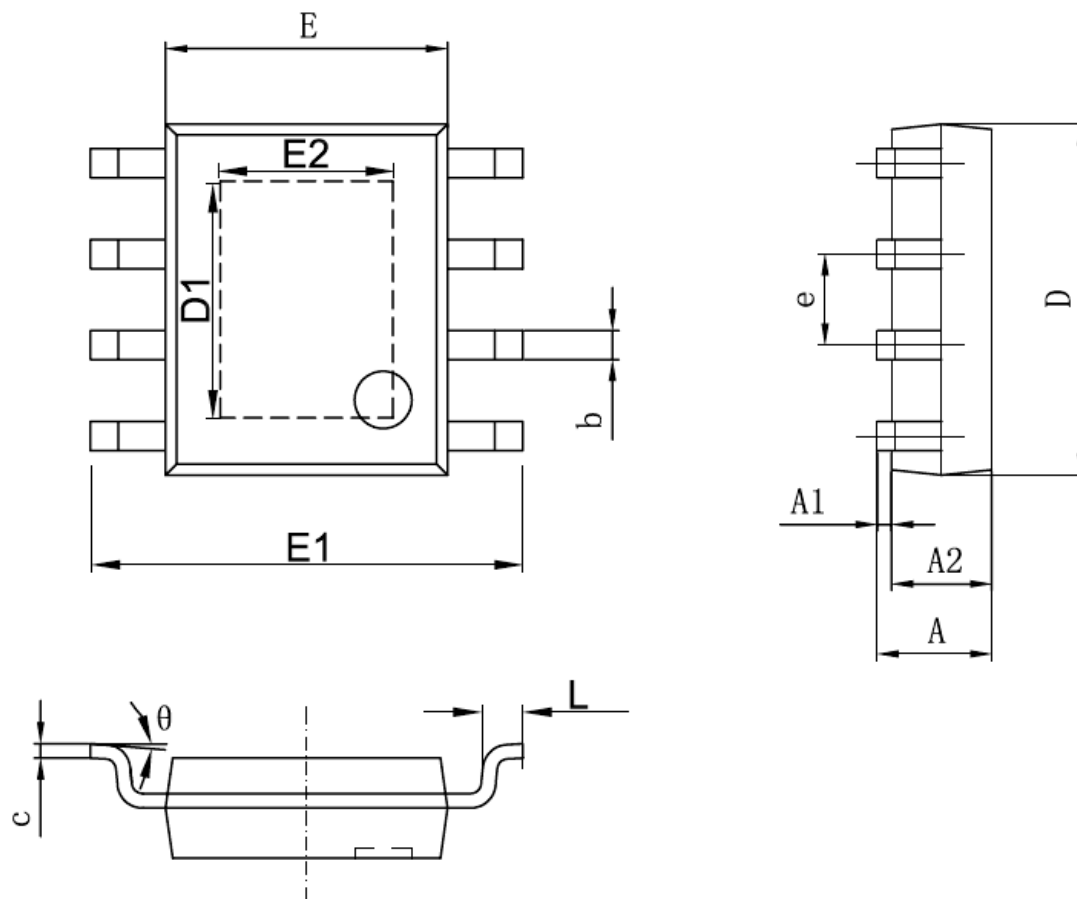

字符	Dimensions In Millimeters		Dimensions In Inches	
	Min	Max	Min	Max
A	1.350	1.70	0.053	0.067
A1	0.00	0.120	0.00	0.005
A2	1.350	1.550	0.053	0.061
b	0.330	0.510	0.013	0.020
c	0.170	0.250	0.006	0.010
D	4.700	5.100	0.185	0.200
D1	3.202	3.402	0.126	0.134
E	3.800	4.000	0.150	0.157
E1	5.800	6.200	0.228	0.244
E2	2.313	2.513	0.091	0.099
e	1.270 (BSC)		0.050 (BSC)	
L	0.400	1.270	0.016	0.050
θ	0°	8°	0°	8°